



Member of the FM Global Group

Examination Standard for Waterflow Detector Check Valves

Class Number 1045

May 2024

Foreword

This standard is intended to verify that the products and services described will meet stated conditions of performance, safety and quality useful to the ends of property conservation. The purpose of this standard is to present the criteria for examination of various types of products and services.

Examination in accordance with this standard shall demonstrate compliance and verify that quality control in manufacturing shall ensure a consistent and reliable product.

Table of Contents

1. INTRODUCTION	1
1.1 PURPOSE	1
1.2 SCOPE.....	1
1.3 BASIS FOR REQUIREMENTS	1
1.4 BASIS FOR CERTIFICATION	1
1.5 BASIS FOR CONTINUED CERTIFICATION	2
1.6 EFFECTIVE DATE.....	2
1.7 SYSTEM OF UNITS.....	2
1.8 NORMATIVE REFERENCES	2
1.9 TERMS AND DEFINITIONS.....	3
2. GENERAL INFORMATION	4
2.1 PRODUCT INFORMATION.....	4
2.2 CERTIFICATION APPLICATION REQUIREMENTS	4
2.3 REQUIREMENTS FOR SAMPLES FOR EXAMINATION	4
3. GENERAL REQUIREMENTS.....	5
3.1 REVIEW OF DOCUMENTATION	5
3.2 PHYSICAL OR STRUCTURAL FEATURES	5
3.3 CLEARANCES	5
3.4 MATERIALS.....	6
3.5 MARKINGS	6
3.6 MANUFACTURER'S INSTALLATION AND OPERATION INSTRUCTIONS	7
3.7 CALIBRATION	7
4. PERFORMANCE REQUIREMENTS	8
4.1 EXAMINATION.....	8
4.2 CLAPPER STRENGTH	8
4.3 RESILIENT SEAT (REVERSE FLOW) LEAKAGE	8
4.4 METAL-TO-METAL (REVERSE FLOW) SEAT LEAKAGE	8
4.5 HYDROSTATIC STRENGTH.....	9
4.6 FRICTION LOSS DETERMINATION.....	9
4.7 DIFFERENTIAL CRACKING PRESSURE	10
4.8 CYCLE TEST.....	10
4.9 BONDING ADEQUACY	11
4.10 WATER ABSORPTION.....	11
4.11 AGING	12
5. MANUFACTURER'S REQUIREMENTS.....	13
5.1 DEMONSTRATED QUALITY CONTROL PROGRAM	13
5.2 SURVEILLANCE AUDIT PROGRAM	14
5.3 PRODUCT MODIFICATION	14
5.4 MANUFACTURING AND PRODUCTION TESTS.....	14
6. BIBLIOGRAPHY.....	14
APPENDIX A: TOLERANCES	15
APPENDIX B: SAMPLE LISTINGS	16
APPENDIX C: DRAWINGS	17

1. INTRODUCTION

1.1 Purpose

- 1.1.1 This standard states testing and certification requirements for waterflow detector check valves. These devices are required by waterworks authorities to supervise private fire service lines in order to detect loss of water through leakage or misuse. Detector check valves permit the flow of water in one direction and prevent flow in the opposite direction. Additionally, these valves direct small flows through a by-pass line that contains a water meter. Large flows for fire protection lift the clapper within the waterflow detector check valve and pass without being metered. When used as part of a compound fire service meter assembly the mainline flow is metered by an upstream mainline meter.
- 1.1.2 Testing and certification criteria may include performance requirements, marking requirements, examination of manufacturing facility(ies), audit of quality assurance procedures, and a surveillance program.

1.2 Scope

- 1.2.1 This standard encompasses the design and performance requirements for 2, 2-1/2, 3, 3-1/2, 4, 5, 6, 8, 10 and 12 in. nominal size waterflow detector check valves for their intended application of permitting flow of water in one direction and preventing flow in the opposite direction while permitting the supervision of private fire service lines in order to detect loss of water through leakage or misuse. Sizes refer to the nominal diameter of the pipeline to which the valve will be connected. Sizes outside the range shown above shall be evaluated on a case-by-case basis. In cases where metric sized waterflow detector check valves are to be examined for certification, test criteria comparable to the equivalent or nearest nominal inch size shall be used.
- 1.2.2 This standard defines the requirements for waterflow detector check valves. Waterflow detector check valves covered in this standard are supplied with either flanged or grooved end connections, and are provided with hand hold covers. Other types of waterflow detector check valves may be certified if they meet the requirements and intent of this standard. Waterflow detector check valves of unusual design may be subjected to special tests to determine their suitability.

1.3 Basis for Requirements

- 1.3.1 The requirements of this standard are based on experience, research and testing, and/or the standards of other organizations. The advice of manufacturers, users, trade associations, jurisdictions and/or loss control specialists was also considered.
- 1.3.2 The requirements of this standard reflect tests and practices used to examine characteristics of waterflow detector check valves for the purpose of obtaining certification.

1.4 Basis for Certification

Certification is based upon satisfactory evaluation of the product and the manufacturer in the following major areas:

- 1.4.1 Examination and tests on production samples shall be performed to evaluate:
- the suitability of the product;
 - the performance of the product as specified by the manufacturer and required for certification;
 - the durability and reliability of the product.

- 1.4.2 An examination of the manufacturing facilities and audit of quality control procedures may be conducted to evaluate the manufacturer's ability to consistently produce the product, which is examined and tested, and the marking procedures used to identify the product. Subsequent surveillance may be required by the certification agency in accordance with the certification scheme to ensure ongoing compliance.

1.5 Basis for Continued Certification

The basis for continual certification may include the following based upon the certification scheme and requirements of the certification agency:

- production or availability of the product as currently certified;
- the continued use of acceptable quality assurance procedures;
- compliance with the terms stipulated by the certification;
- satisfactory re-examination of production samples for continued conformity to requirements; and
- satisfactory surveillance audits conducted as part of the certification agency's product surveillance program.

1.6 Effective Date

The effective date of this examination standard mandates that all products tested for certification after the effective date shall satisfy the requirements of this standard.

The effective date of this standard is eighteen (18) months after the publication date of the standard for compliance with all requirements.

1.7 System of Units

Units of measurement used in this standard are United States (U.S.) customary units. These are followed by their arithmetic equivalents in International System (SI) units, enclosed in parentheses. The first value stated shall be regarded as the requirement. The converted equivalent value may be approximate. Conversion of U.S. customary units is in accordance with ANSI/IEEE/ASTM SI 10.

Two units (liter and bar), outside of but recognized by SI, are commonly used in international fire protection and are used in this standard.

1.8 Normative References

The following documents are referred to in the text in such a way that some or all of their content constitutes requirements of this document. For dated references, only the cited edition applies:

ANSI/ASME B16.5, Pipe Flanges and Flanged Fittings

ANSI/IEEE/ASTM SI, American National Standard for Metric Practice

ASTM D 471, Standard Test Method for Rubber Property - Effect of Liquids

ASTM D 572, Standard Test Method for Rubber - Deterioration by Heat and Oxygen

AWWA C606, Joints, Grooved and Shouldered Type

1.9 Terms and Definitions

For purposes of this standard, the following terms apply:

Accepted

This term refers to installations acceptable to the authority enforcing the applicable installation rules. Acceptance is based upon an overall evaluation of the installation. Acceptance is not a characteristic of a product. It is installation specific. A product accepted for one installation may not be acceptable elsewhere.

Corrosion resistant

Having resistance to corrosion equal to or exceeding that of a bronze alloy having a minimum copper content of 80 percent, or constructed of 300 or 400 series stainless steel.

End Connections

The method of connecting components of a pipe system to the ends of the valve.

Flanged End Valve

Valves having mating flanged ends per the dimensional values shown in ANSI/ASME B16.5. Flanges to other national or international standards shall be evaluated on a case-by-case basis.

Grooved End Valves

A grooved end valve is characterized by having grooved ends on the inlet and outlet ends of the valve body such that the valve may be installed in the sprinkler system piping using certified grooved end couplings. For the purpose of this standard, grooves shall comply to the dimensional values shown in AWWA C606. Grooves to dimensions of other standards will be reviewed on a case-by-case basis.

Hand Hole Cover

A removable cover, which when removed, allows replacement of internal parts without having to remove the valve from the pipe line.

Rated Working Pressure

The maximum sustained pressure at or below which the valve shall operate trouble free.

Waterflow Detector Check Valve

A valve with an inherent design characteristic that permits flow of water in one direction and prevents flow in the opposite direction under cyclic pressure conditions. Additionally, these valves direct small flows through a by-pass line that contains a water meter. Large flows for fire protection lift the clapper of the detector check valve and pass without being metered. When used as part of a compound fire service meter assembly the mainline flow is metered by an upstream mainline meter.

2. GENERAL INFORMATION

2.1 Product Information

- 2.1.1 These valves typically consist of an assembly of the following components: body, spring, disc/clapper, seat ring, seal facing, lifting lug, hand hold cover, hinge pin and by-pass including water meter and check valve.
- 2.1.2 In order to meet the intent of this standard, waterflow detector check valves must be examined on a model-by-model, type-by-type, manufacturer-by-manufacturer, and plant-by-plant basis. This is predicated on the basis that identical designs, fabricated in identical materials by different manufacturers or, even by different plants of the same manufacturer, have been seen to perform differently in testing. Sample valves, selected in conformance to this criterion, shall satisfy all of the requirements of this standard.

2.2 Certification Application Requirements

The manufacturer shall provide the following preliminary information with any request for certification consideration:

- a complete list of all models, types, sizes, and options for the products or services being submitted for certification consideration,
- general assembly drawings, one complete set of manufacturing drawings, materials list(s), anticipated marking format, brochures, sales literature, specification sheets, installation, operation and maintenance procedures,
- the number and location(s) of manufacturing facilities.

All documents shall identify the manufacturer's name, document number or other form of reference, title, date of last revision, and revision level. All foreign language documents shall be provided with English translation.

2.3 Requirements for Samples for Examination

- 2.3.1 Following authorization of certification examination, the manufacturer shall submit samples for examination and testing based on the following:

Sample requirements to be determined by the certification agency.

- 2.3.2 Requirements for samples may vary depending on design features, results of prior or similar testing, and results of any foregoing tests.
- 2.3.3 The manufacturer shall submit samples representative of production.
- 2.3.4 It is the manufacturer's responsibility to provide any necessary test fixtures, such as those which may be required to evaluate the fire service meters.

3. GENERAL REQUIREMENTS

3.1 Review of Documentation

- 3.1.1 During the initial investigation and prior to physical testing, the manufacturer's specifications, technical data sheets, and design details shall be reviewed to assess the ease and practicality of installation and use. The product shall be capable of being used within the limits of the certification investigation.

3.2 Physical or Structural Features

- 3.2.1 Valves shall be designed for a minimum rated working pressure of 175 psi (1205 kPa).
- 3.2.2 End connections shall be flanged or grooved and shall conform to a nationally or internationally recognized standard. Other types of end connections shall be evaluated on a case-by-case basis.
- 3.2.3 Replaceable internal parts shall be removable through an opening in the body without having to remove the valve from the pipe line. A suitable gasketed hand hole cover shall be provided for the opening.
- 3.2.4 Valves having a single hinge pin side plug shall provide hinge pins which have tapped holes at each end for ease of removal.
- 3.2.5 Clapper parts shall be assembled in such a manner that they will not separate in reasonable cycling pressure service.
- 3.2.6 Valves incorporating clapper weights shall be designed such that the clapper weight is located inside the valve body.
- 3.2.7 Valves which employ springs to aid in closing the valve shall be capable of 50,000 cycles of full travel without damage to or failure of the spring or any other valve component.
- 3.2.8 The pressure drop across the clapper required to lift it off its seat shall be not less than 1.5 psi (10 kPa) and not more than 3.0 psi (21 kPa).
- 3.2.9 The body shall be provided with two ports on each side in order to permit the installation of either a right or left hand by-pass line. These ports shall be furnished with 2 inch maximum threaded pipe outlets.
- 3.2.10 There shall be a manually operated control valve upstream of the by-pass meter and a swing check valve or manually operated control valve in the by-pass line downstream of the by-pass meter in order to isolate the bypass meter to allow removal for repairs without impairment of the fire protection system.
- 3.2.11 The by-pass meter sizes commonly used are: 1, 1-1/2 or 2 inch NPS. The size shall be determined by the requirements of the authority having jurisdiction.
- 3.2.12 Valves submitted for testing shall be true production samples and shall be free of sharp edges, burrs, or other imperfections which might injure the installer or interfere with proper assembly of the unit.

3.3 Clearances

- 3.3.1 Ample clearances shall be provided between all moving and stationary components so that corrosion or deposits such as tuberculation will not interfere with proper operation of the valve.

3.3.2 To assure ample clearance, the following minimum dimensions shall be maintained:

- The clearances between the periphery of the clapper and the inside of the body in every position of the clapper from “closed” to “ full open” shall be at least 3/4 inch (19 mm). For valves incorporating corrosion resistant clappers and bodies, the clearance requirement shall be 3/8 inch (10 mm). See Figure C-1 in Appendix C.
- There shall be a clearance of at least 1/2 inch (13 mm) between the hub of the clapper arm and the inside of the body. For valves incorporating corrosion resistant clappers and bodies, the clearance requirements shall be 3/8 inch (10 mm). See Figure C-2 in Appendix C.
- The width of the hub of the clapper arm shall be at least 1/8 inch (3 mm) less than the minimum distance between the hinge pin bearings. See Figure C-3 in Appendix C.
- There shall be a diametrical clearance of at least 0.015 in. (0.4 mm) between the outside diameter of the hinge pin and the inside diameter of the hole in the hinge pin bearing. See Figure C-3 in Appendix C.
- There shall be a minimum 1/8 inch (3 mm) projection of hinge pin bushings beyond the supporting material.
- No allowance or reduction in tolerances are allowed for coatings applied to iron components.

3.4 Materials

All materials used in these valves shall be suitable for the intended application. Particular consideration shall be given to the corrosion resistance of the materials used as contact surfaces between rotating or moving and stationary parts. When unusual materials are used, special tests may be necessary to verify their suitability.

3.5 Markings

3.5.1 Marking on the product or, if not possible due to size, on its packaging or label accompanying the product, shall include the following information:

- name and address of the manufacturer or marking traceable to the manufacturer;
- date of manufacture or code traceable to date of manufacture or lot identification;
- model number, size, rated working pressure, directional flow arrow.

When hazard warnings are needed, the markings should be universally recognizable.

3.5.2 Markings shall be cast or forged in raised characters or die stamped on the valve body or cover or both. All letters and symbols shall be large enough to be read by a person with normal vision (20/20 corrected) standing 3 ft. (0.9 m) away.

3.5.2.1 A corrosion resistant metal nameplate bearing the same information as stated above shall be considered acceptable if permanently fastened to the valve body or cover.

3.5.2.2 Other methods of applying permanent markings will be evaluated on a case by case basis.

3.5.3 Each required marking shall be legible and durable and applied in any of, or combination of, the above methods with the exception of the directional flow arrow which must be applied as stated in Section 3.5.2.

3.5.4 The model or type identification shall correspond with the manufacturer's catalog designation and shall uniquely identify the certification agency's mark of conformity.

3.5.5 The certification agency's mark of conformity shall be displayed visibly and permanently on the product and/or packaging as appropriate and in accordance with the requirements of the certification

agency. The manufacturer shall exercise control of this mark as specified by the certification agency and the certification scheme.

3.6 Manufacturer's Installation and Operation Instructions

3.6.1 The manufacturer shall

- prepare instructions for the installation, maintenance, and operation of the product;
- provide facilities for repair of the product and supply replacement parts; and
- provide services to ensure proper installation, inspection, or maintenance for products where it is not reasonable to expect the average user to be able to provide the installation, inspection, or maintenance.

3.7 Calibration

3.6.1 Each piece of equipment used to verify the test parameters shall be calibrated within an interval determined on the basis of stability, purpose, and usage. A copy of the calibration certificate for each piece of test equipment is required. The certificate shall indicate that the calibration was performed against working standards whose calibration is certified and traceable to an acceptable reference standard and certified by an ISO/IEC 17025 accredited calibration laboratory. The test equipment shall be clearly identified by label or sticker showing the last date of the calibration and the next due date. A copy of the service provider's accreditation certificate as an ISO/IEC 17025 accredited calibration laboratory should be available.

3.6.2 When the inspection equipment and/or environment is not suitable for labels or stickers, other methods such as etching of control numbers on the measuring device are allowed, provided documentation is maintained on the calibration status of the equipment.

4. PERFORMANCE REQUIREMENTS

4.1 Examination

4.1.1 Requirements

The waterflow detector check valves shall conform to the manufacturer's drawings and specifications and to certification requirements.

4.1.2 Test/Verification

A sample shall be examined and compared to drawings and specifications. It shall be verified that the sample conforms to the physical and structural requirements described in Section 3, General Requirements.

4.2 Clapper Strength

4.2.1 Requirements

The valve clapper shall withstand exposure to hydrostatic pressure of two times the rated working pressure. During and at the conclusion of the test, no fracture, permanent distortion, or functional impairment shall occur. After this test, the valve shall be fully operable and shall comply with the leakage requirements in Section 4.3 (Resilient Seat Leakage) or Section 4.4 (Metal-To-Metal Seat Leakage), as applicable.

4.2.2 Test/Verification

A hydrostatic pressure of two times the rated working pressure shall be applied to the outlet side of the valve with the inlet of the valve open to atmosphere. The test pressure shall be held for five minutes. During and at the conclusion of the test, no fracture, permanent distortion or functional impairment shall occur. Full compliance with Section 4.3 (Resilient Seat Leakage) or Section 4.4 (Metal-To-Metal Seat Leakage) is required after the clapper strength test.

4.3 Resilient Seat (Reverse Flow) Leakage

4.3.1 Requirements

Resilient seated valves shall be leak tight when subjected to downstream hydrostatic test pressures ranging from 30 psi (205 kPa) to the rated working pressure.

4.3.2 Test/Verification

With the inlet side open to atmosphere, the downstream side of each size valve shall be subjected to hydrostatic pressures of 30, 100 and 175 psi (205, 690 and 1205 kPa) and at the rated working pressure if in excess of 175 psi (1205 kPa). The test pressures shall each be held for five minutes, with no leakage allowed.

4.4 Metal-To-Metal (Reverse Flow) Seat Leakage

4.4.1 Requirement

Metal-to-metal seated valve leakage shall not exceed 1 fluid ounce/hr (30 ml/hr) per inch of nominal valve size when subjected to downstream hydrostatic test pressures ranging from 30 psi (205 kPa) to the rated working pressure.

4.4.2 Test/Verification

With the inlet side open to atmosphere, the downstream side of each valve shall be subjected to hydrostatic pressures of 30, 100 and 175 psi (205, 690 and 1205 kPa) and at the rated working pressure if in excess of 175 psi (1205 kPa). The test pressures shall each be held for five minutes. Slight leakage, not in excess of 1 fluid ounce/hr (30 ml/hr) per inch of nominal valve size, is allowed.

4.5 Hydrostatic Strength

4.5.1 Requirements

Valve bodies shall withstand a hydrostatic pressure of four times the rated working pressure without rupture, cracking or permanent distortion.

4.5.2 Test/Verification

With the clapper removed or blocked off its seat, valve bodies of each valve size and end connection style, shall be subjected to a hydrostatic test pressure of 700 psi (4825 kPa), or four times the rated working pressure, whichever is greater, for a duration of five minutes. There shall be no visible rupture, cracking or permanent distortion of the valve body.

4.6 Friction Loss Determination

4.6.1 Requirement

The construction of the valve shall be such that obstruction to the passage of water through the valve body is minimal. With the clapper or disc in the full open position, the loss of pressure through the valve shall not exceed 5.0 psi (35 kPa) at a flow producing a velocity of 20 ft/sec (6.1 m/s) in Schedule 40 steel pipe of the same nominal diameter as the valve.

4.6.2 Test/Verification

Tests shall be conducted to verify that the friction loss through each nominal size valve does not exceed 5.0 psi (35 kPa) at the flow rates shown in Table 4.6.2. These flows have been calculated based on a fluid velocity of 20 ft/sec (6.1 m/s) in Schedule 40 steel sprinkler pipe. This test may be waived at the examining engineer’s option if drawing and calculation reviews of manufacturer’s flow data are satisfactory (Note: For valves larger than 12 in. nominal size, it shall be the responsibility of the manufacturer to submit friction loss data or calculations showing compliance.) For valves corresponding to metric sizes, the manufacturer shall indicate the metric pipe to be used in the evaluation.

Table 4.6.2. - Friction Loss Flows

<i>Nominal Valve Size, in.</i>	<i>Flow at Velocity of 20 ft/sec (6.1 m/sec),</i>	
	<i>gal/min</i>	<i>(L/min)</i>
2	210	(795)
2-1/2	300	(1135)
3	460	(1740)
3-1/2	615	(2330)
4	795	(3010)
5	1245	(4715)
6	1800	(6815)

<i>Nominal Valve Size, in.</i>	<i>Flow at Velocity of 20 ft/sec (6.1 m/sec),</i>	
	<i>gal/min</i>	<i>(L/min)</i>
8	3120	(11 810)
10	4915	(18 605)
12	7050	(26 685)
14	8450	(31 985)
16	11,000	(41 640)
18	14,000	(52 995)
20	17,500	(66 245)
24	25,000	(94 635)

4.7 Differential Cracking Pressure

4.7.1 Requirements

The pressure differential across the clapper needed to lift the clapper from its seat shall be not less than 1.5 psi (10 kPa) and not more than 3.0 psi (21 kPa).

4.7.2 Test/Verification

One sample of each size valve shall be placed in a level horizontal position. Both the inlet and outlet ends shall be capped with shut off valves. Transparent sight glasses, open to atmosphere and approximately 8 feet (2.4 m) long, shall be installed vertically to both upstream and downstream chambers of the valve seat. With the outlet shut off valve closed, the valve shall be purged of all entrapped air by flowing water through the inlet shut off valve. The inlet shall be pressurized until the upstream sight glass reaches a height of 83 inches (211 cm) of water higher than the water level in the downstream site glass. The inlet shut off valve shall then be closed. The decrease in water level in the inlet site glass shall be monitored until no further fall of water is observed. The difference in water levels between the upstream and downstream site glasses shall be recorded. The distance between the two water levels must be greater than 41.5 inches (106 cm) and less than 83.1 inches (211 cm).

4.8 Cycle Test

4.8.1 Requirements

Waterflow detector check valves which employ springs on the clapper shall be capable of 50,000 cycles of normal operation without excessive wear, damage or failure of any valve component.

4.8.2 Test/Verification

A sample valve of each size shall be cycled 50,000 times, at a rate not exceeding 6 cycles per minute, through its full range of travel in a static air environment. This test shall be conducted at atmospheric (0 psi, 0 kPa) conditions. After the completion of the cycling test, the valve shall be disassembled. Parts shall be visibly examined for signs of excessive wear, damage or failure. This test, or a portion thereof, may be waived if a design and calculation review are satisfactory.

4.9 Bonding Adequacy

4.9.1 Requirement

For resilient seated valves, rubber facings shall remain securely bonded or fastened to the disc/clapper base material.

4.9.2 Test/Verification

A representative size valve shall be subjected to a flow rate producing a velocity of 30 ft/sec (9 m/sec) in Schedule 40 steel pipe of the same nominal diameter as the valve for 90 minutes. These flow rates are shown in Table 4.9.2. Following this test, there shall be no apparent separation of the rubber from the base material or substrate or any other type of failure, such as blistering, peeling, flaking, delaminating, or evidence of loosening from the base material or of any hardware used to secure the rubber facing.

Table 4.9.2 - Bonding Adequacy Flows

<i>Nominal Valve Size, in.</i>	<i>Flow at Velocity of 30 ft/sec (9 m/sec),</i>	
	<i>gal/min</i>	<i>(L/min)</i>
2	315	(1190)
2-1/2	450	(1695)
3	690	(2615)
3-1/2	925	(3500)
4	1190	(4505)
5	1870	(7080)
6	2700	(10 225)
8	4680	(17 705)
10	7375	(27 910)
12	10 465	(39 620)
14	12 650	(47 880)
16	16 525	(62 550)
18	20 915	(79 170)
20	25 990	(98 380)
24	37 590	(142 290)

4.10 Water Absorption

4.10.1 Requirement

For resilient seated valves, water absorption of the rubber facings shall not result in changes that exceed 1.5 percent of the original thickness or weight.

4.10.2 Test/Verification

A specimen of the valve rubber facing supplied by the manufacturer shall be maintained in water at a temperature of 212 °F (100 °C) for 6 hours to measure the comparative ability of rubber to withstand the effect of water in accordance with ASTM D 471, Standard Test Method for Rubber Property - Effect of Liquids. At the end of this period, a change in the thickness or weight of the sample shall not exceed 1.5 percent of the original thickness or weight.

4.11 Aging

4.11.1 Requirement

For resilient seated valves, aging shall not promote cracking of the rubber facings.

4.11.2 Test/Verification

A specimen of the valve rubber facing, approximately 1 x 3 inches (25 x 75 mm) by 1/8 in. (3 mm) thick, supplied by the valve manufacturer shall be subjected to an accelerated aging test in accordance with ASTM D 572, Standard Test Method for Rubber - Deterioration by Heat and Oxygen. The test duration shall be 96 hours. After the test, the specimen shall be examined for resilience. No cracking shall occur when the sample is bent double, (i.e. bend radius of 180°)

5. MANUFACTURER'S REQUIREMENTS

5.1 Demonstrated Quality Control Program

5.1.1 A quality assurance program is required to assure that subsequent products produced by the manufacturer shall present the same quality and reliability as the specific products examined. Design quality, conformance to design, and performance are the areas of primary concern.

- Design quality is determined during the examination and tests, and is documented in the certification report.
- Continued conformance to this standard is verified by the certifier's surveillance program.
- Quality of performance is determined by field performance and by periodic re-examination and testing.

5.1.2 The manufacturer shall demonstrate a quality assurance program which specifies controls for at least the following areas:

- existence of corporate quality assurance guidelines;
- incoming quality assurance, including testing;
- in-process quality assurance, including testing;
- final inspection and tests;
- equipment calibration;
- drawing and change control;
- packaging and shipping; and
- handling and disposition of non-conforming materials.

5.1.3 Documentation/Manual

There should be an authoritative collection of procedures/policies. It should provide an accurate description of the quality management system while serving as a permanent reference for implementation and maintenance of that system. The system should require that sufficient records are maintained to demonstrate achievement of the required quality and verify operation of the quality system.

5.1.4 Records

There should be an authoritative collection of procedures/policies. It should provide an accurate description of the quality management system while serving as a permanent reference for implementation and maintenance of that system. The system should require that sufficient records are maintained to demonstrate achievement of the required quality and verify operation of the quality system.

5.1.5 Drawing and Change Control

The manufacturer shall establish a system of product configuration control that shall allow no unauthorized changes to the product. Changes to critical documents, identified in the certification report, may be required to be reported to, and authorized by the certification agency prior to implementation for production.

Records of all revisions to all certified products shall be maintained.

5.2 Surveillance Audit Program

- 5.2.1 An audit of the manufacturing facility may be part of the certification agency's surveillance requirements to verify implementation of the quality assurance program. Its purpose is to determine that the manufacturer's equipment, procedures, and quality program are maintained to ensure a uniform product consistent with that which was tested and certified.
- 5.2.2 Certified products or services shall be produced or provided at, or provided from, location(s) disclosed as part of the certification examination. Manufacture of products bearing a certification mark is not permitted at any other location prior to disclosure to the certification agency.

5.3 Product Modification

The manufacturer shall notify the certification agency of changes in product construction, components, raw materials, physical characteristics, coatings, component formulation or quality assurance procedures prior to implementation.

5.4 Manufacturing and Production Tests

5.4.1 Test Requirement No. 1 - *Seat Leakage*

The manufacturer shall test 100 percent of production valves for seat leakage to the rated working pressure. The pressure shall be held for a minimum of 15 seconds. If there is no visible leakage after 15 seconds, then the test may be considered acceptable. For metal seated valves, only, if there is leakage visible during the 15 second test, then the test duration shall be extended to a minimum of 1 minute so that the leakage rate can be determined. If the metal seated valve is observed to have leakage in excess of 1 fluid ounce/hr (30 ml/hr) for each inch of valve size, the valve is considered to have failed the test. Resilient-seated valves of any size shall have no visible leakage.

Following the seat leakage test, all valves shall be opened through their full range with no evidence of sticking or binding.

5.4.2 Test Requirement No. 1 – *Body Leakage*

The manufacturer shall test 100 percent of production valves for body leakage to twice the rated working pressure. The pressure shall be held for a minimum of 1 minute with no evidence of body leakage or distortion.

6. BIBLIOGRAPHY

ANSI/ASME B1.20.1, Pipe Threads, General Purpose (Inch) and Redesignation of ASME/ANSI B2.1

ISO 17025, *General Requirements for the Competence of Testing and Calibration Laboratories*

APPENDIX A: Tolerances

Unless otherwise stated, the following tolerances shall apply:

Angle: $\pm 2^\circ$

Frequency (Hz): ± 5 percent of value

Length: ± 2 percent of value

Volume: ± 5 percent of value

Volume Per Unit Area: ± 5 percent of value

Pressure: + 5 percent of value
- 0 percent of value

Temperature: $\pm 4^\circ\text{F}$ (2°C)

Time: + 5/-0 seconds
+0.1/-0 minutes

Unless stated otherwise, all tests shall be carried out at a room (ambient) temperature of $68 \pm 9^\circ\text{F}$ ($20 \pm 5^\circ\text{C}$).

APPENDIX B: Sample Listings

Company Name and Address

<i>Product Designation</i>	<i>Valve Size, in.</i>	<i>Flow Rate gal/min (dm³/min)</i>	<i>Friction Loss, psi (kPa)</i>	
XYZ	4	500	2.5	
		(1895)	(17.0)	
		750	2.8	
			(2840)	(19.5)
			1000	3.2
			(3785)	(22.0)
	6	1000	1000	1.8
			(3785)	(12.5)
		1500	1500	2.4
			(5680)	(16.5)
	8	2000	2000	3.0
			(7570)	(20.7)
		3000	3000	3.1
			(7570)	(21.5)
		4000	4000	3.9
			(11 355)	(27.0)
	10	2250	2250	4.5
			(15 140)	(31.0)
4500		4500	1.9	
		(8515)	(13.0)	
6000		1.9		
(17 035)	(13.0)			
6000	1.8			
(22 710)	(12.5)			

APPENDIX C: Drawings

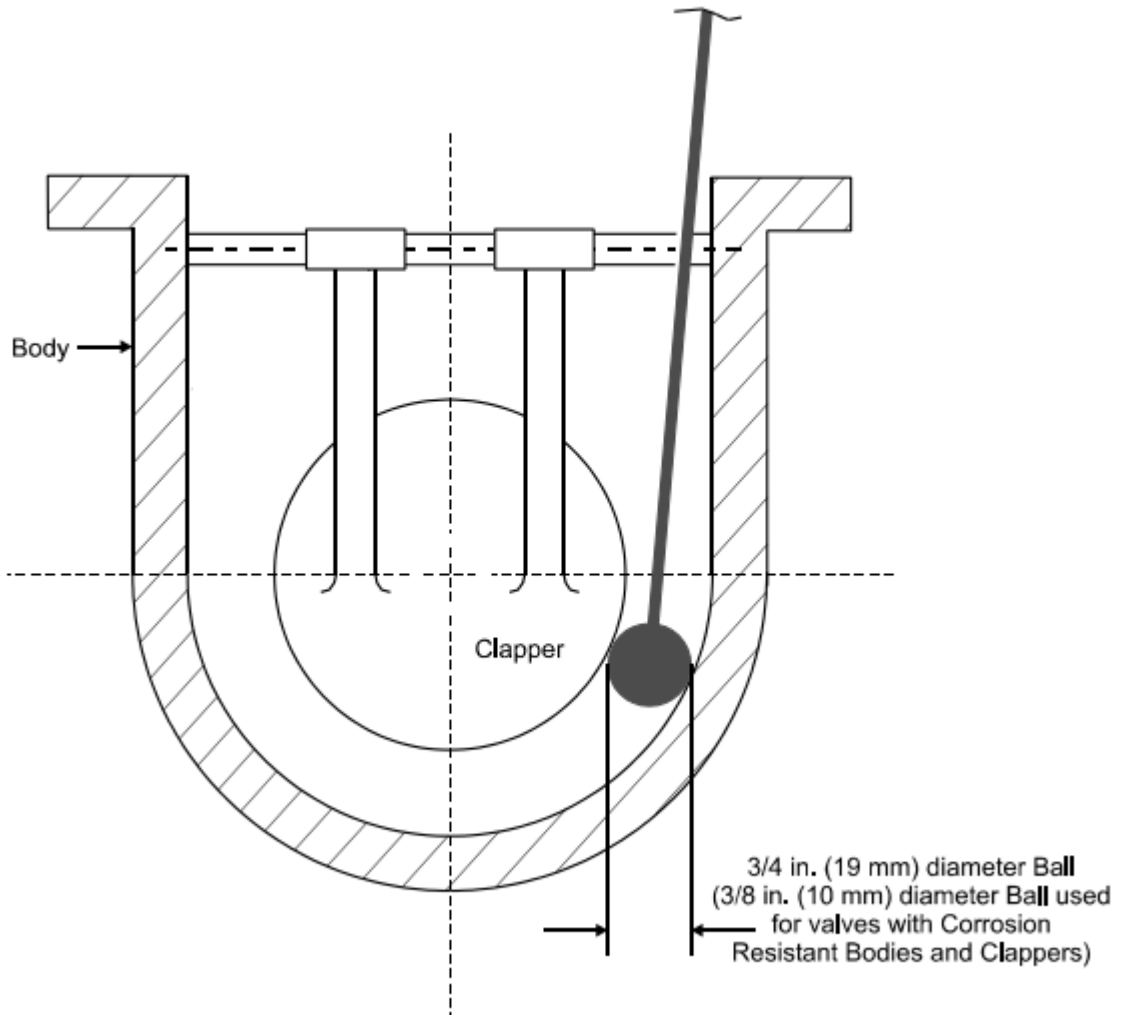

Figure C-1: Clearances

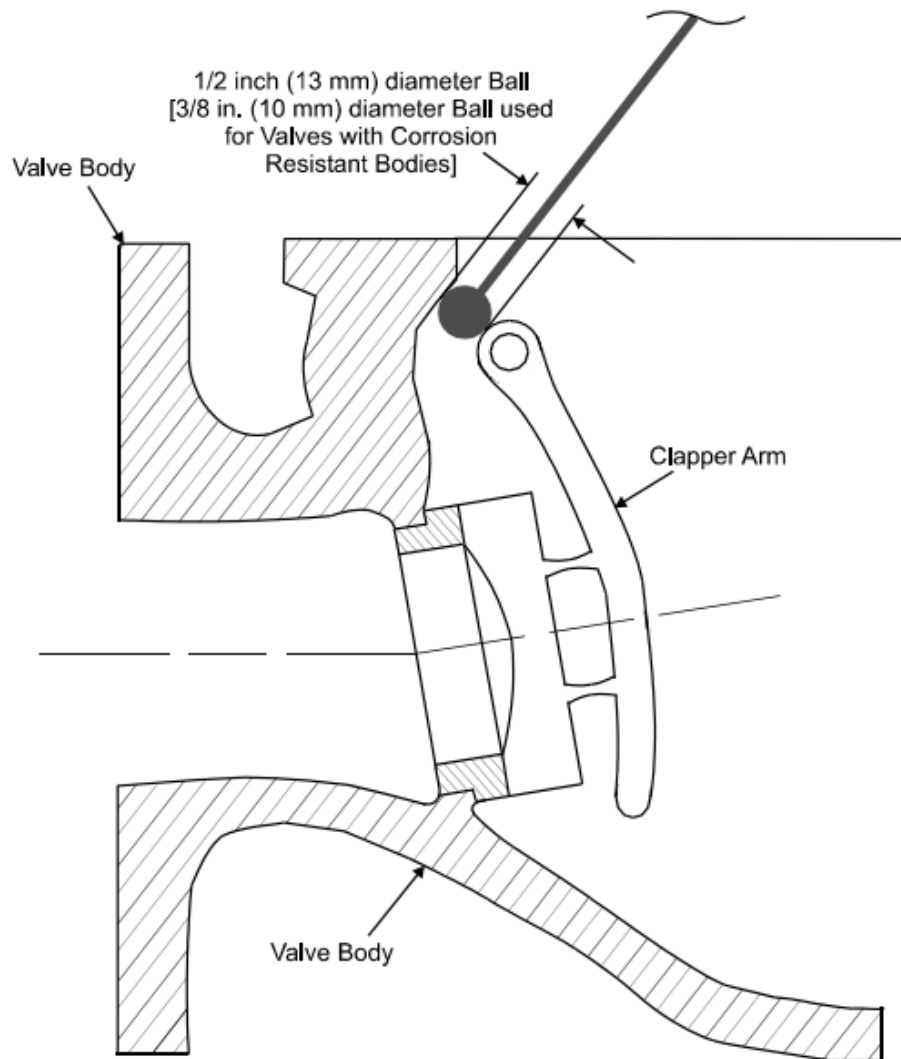

Figure C-2: Clearances

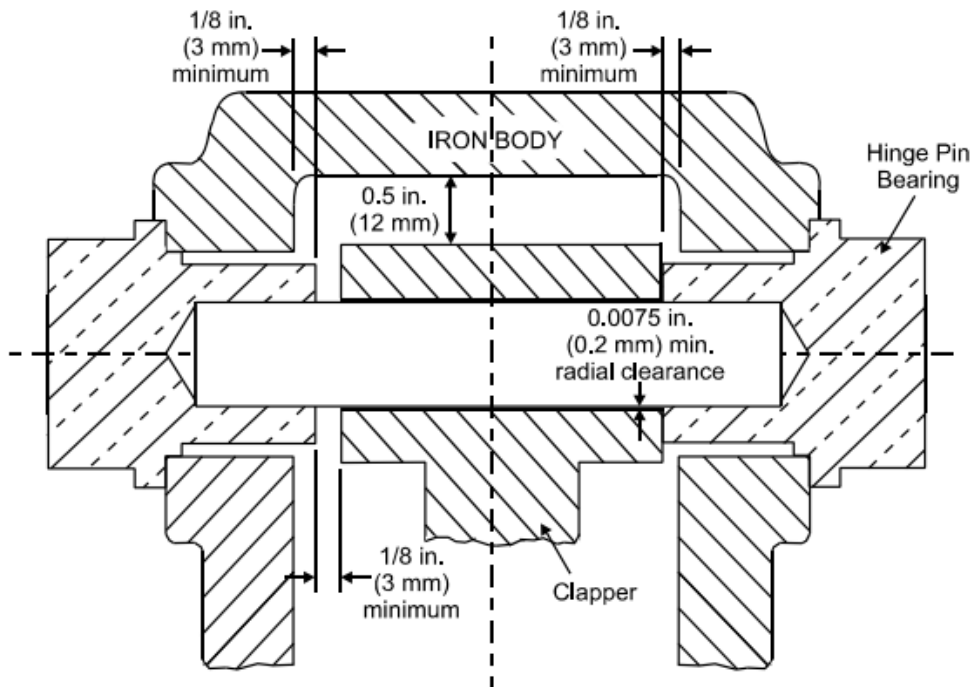

Figure C-3: Clearances